

Sunex

Excellence in Optical Design and Manufacturing

SENSOR MODULES™

Sensor Board and Active Alignment Services

25+ year track record of success in taking customer concepts from design through mass production.





SUNEX SENSOR MODULES™

Depending on the requirements, we can provide design and manufacturing services for a complete sensor module. We strive to find the best solution for your needs, from designing the schematic, creating the PCB layout, and sourcing all components to building according to your PCB design and parts consignment.

At Sunex, we have the in-house expertise and capabilities for lens and sensor board design, high-volume manufacturing, automated active alignment, and testing to support the most demanding vision applications.

For additional services, we can bring in partners from our Technology and Service Network that allow us to process bare die and packaged sensors, including cabling options, e.g., for medical applications, and hand over the complete tested sensor module to the following entity in the value chain to integrate the full camera.

Designed for Mass Production

Often it is not the challenge to create a design “that works” but to find a solution that can scale to mass production, meeting price targets, optical performance, mechanical constraints, and quality requirements. Sunex has over two decades of design and manufacturing experience, and all our lenses and modules are designed for high-volume manufacturability.

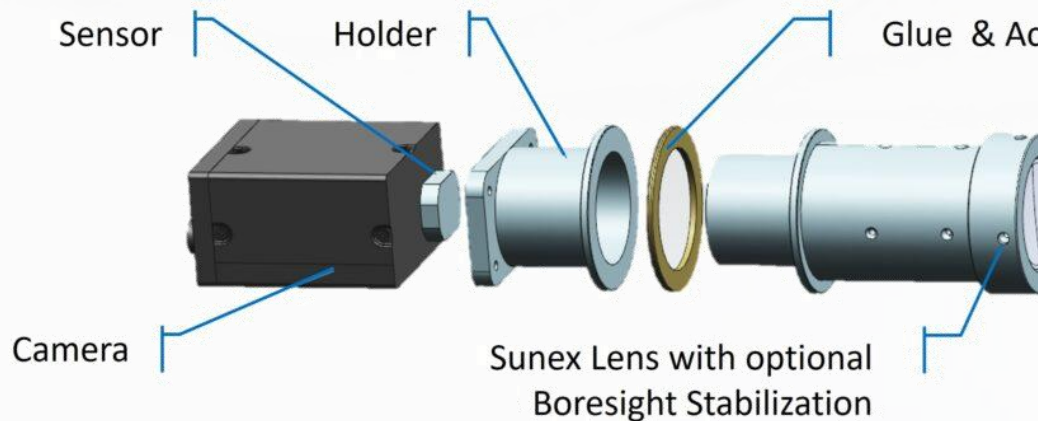
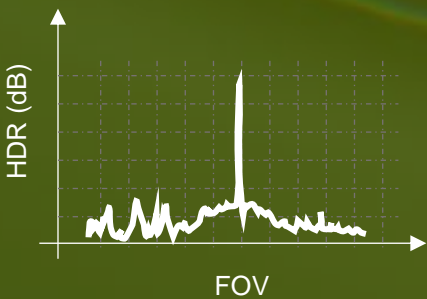
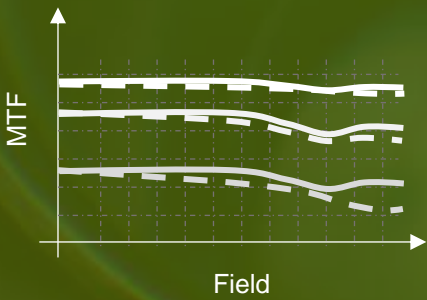
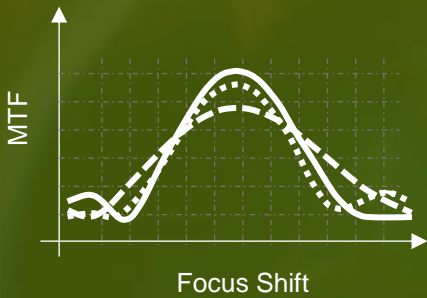

All graphs are for illustration purpose only. The individual lens performance can be different.



PCBA

Designed by Sunex
DFM of 3rd party layout
Consigned with IQC



CMOS

Bare Die and Packaged
Procured by Sunex
Consigned by 3rd party

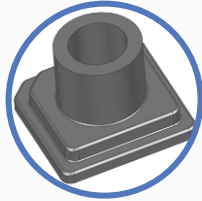

OptoMech

Holder & Unibody
Metal & Plastic
Athermalized



Active Alignment

5-axis Manual AA
6-axis Automated AA
Hybrid Mode

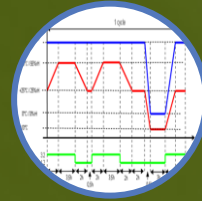

REL

Shock & Vibration
Environmental
Lifetime



System

Housing
Cabling
Sub-Assembly

Active Alignment Capabilities

We recommend that our customers consider an active alignment process to achieve the highest system performance when pairing a high-quality lens with a high-resolution sensor. Our active alignment offering can grow with the ramp of the program and enables the use of an alignment process from the beginning. Applying a fully automated 6-axis active alignment in mass production increases yield, shortens cycle times, improves system performance, and lowers part-to-part variance.

Fast Prototyping

We provide prototyping services for complete lens assemblies often as the first step after a new custom design.

Sunex can produce prototypes with short lead times to verify the design before transitioning further on the path to mass production using state-of-the-art fabrication processes for glass and plastic optical elements and all mechanical components.

Active Alignment

Empower your application with

SENSOR MODULES™

sunex.com/solutions

Consulting – Design – Manufacturing - Support



SUNEX INC.

3160 Lionshead Ave, Suite B

Carlsbad, CA 92010, USA

Tel: +1 760-597-2966

sunex.com/contact